



Centre Region Council of Governments

REGIONAL REFUSE AND RECYCLING PROGRAM

<http://crcog.net/refuse>

2643 Gateway Drive, Suite 3 • State College, PA 16801-3092
Phone: (814) 234-7198 • Fax: (814) 231-3083 • Email: recycler@crcog.net

Refuse and Recycling Building Design Guidelines

Small/Medium Retail: Dumpster facilities should accommodate a regular refuse dumpster and a cardboard-OCC Dumpster or customer provided container. Also, there should be space for a minimum of 3 Carts for Mixed Paper and metal and plastic containers.

Large Retail: Dumpster facilities should accommodate a regular refuse dumpster or refuse compactor. If cardboard-OCC is not being bailed internally, space for an OCC dumpster or compactor is also warranted. Also, there should be space for a minimum of 4 recycling carts for METAL and PLASTIC and MIXED PAPER.

Class 1 Office Space: Dumpster facilities should accommodate a regular refuse dumpster. OCC may be needed if receive boxed goods. Also, there should be space for a minimum of 4 recycling carts for METAL and PLASTIC and MIXED PAPER.

Industrial: Dumpster facilities should accommodate a regular refuse dumpster and an OCC Dumpster. Based on the industry and # of employees, additional recycling carts may or may not be warranted.

Standalone Restaurant, no bar: Dumpster facilities should accommodate a regular refuse dumpster and an OCC Dumpster. Also, there should be space for 3 - 4 recycling carts for METAL and PLASTIC and possibly GLASS.

Bar or Restaurant/Bar: Dumpster facilities should accommodate a regular refuse dumpster and an OCC Dumpster. Also, there should be space for a minimum of 5 recycling carts for the three types of GLASS, METAL and PLASTIC. Depending on size and type of restaurant, more carts will be needed.

Mixed Use: Dumpster facilities should have space for regular and OCC dumpsters. Also, space for 6 carts is warranted if a large mixed use design is planned.

Dumpster Dimensions

<u>Size</u>	<u>Width</u>	<u>Length</u>	<u>Height</u>
4 yard	6 ft. 8 in.	4 ft. 9 in.	5 ft. 4 in.
6 yard	6 ft. 8 in.	6 ft. 6 in.	5 ft. 4 in.
8 yard	6 ft. 8 in.	7 ft. 6 in.	6 ft. 3 in.



Container Dumpster Dimension

- 8 Yard, 7' x 7'
- Plan for space around for people to deposit cardboard & for truck to pick up, dump and place back down.
- Truck 35' long, ideally no angle required for collection
- Estimate of cost: \$50/month for weekly pickup



Recycling Cart Dimensions

Blue Carts for each: Mixed Office Paper, Plastic Bottles, and Aluminum/Steel Cans. When glass use is generally not high then include space for a 15-30 gallon bin (like residential red bin) is acceptable.

- 28" w x 36" d x 48" h; 96 gallon capacity
- Truck uses a side lift to dump each cart. Carts have wheels and the driver collects the carts and attaches them to the truck.
- Estimate of cost: \$45/month for weekly collection



WASTE CORRAL DIMENSIONS: In most cases 20' (w) x 15' (d) is the ideal size, with two 10' gates.

Always place trash and recycling adjacent to each other. People will generally take all waste to the nearest container, regardless of its designation.

CLEARANCES: 1' between bins and enclosure walls, 4' user aisle between bins
An area that is 150% of the sum of container and toter footprints should suffice.

TRUCK ACCESS

Pad in front of where dumpster sits should be built to handle heavy duty trucks – 8-10" thickness reinforced concrete. This is the area where the truck (and all the weight) is. Inside turning radius: 24' – 30' depending on site

EMERGENCY VEHICLE ACCESS

Having the dumpsters positioned to best facilitate pick-up and replacement is generally in the best interest of all so that emergency vehicles can always get where they need. It is not acceptable to have dumpsters protrude into the travel ways.

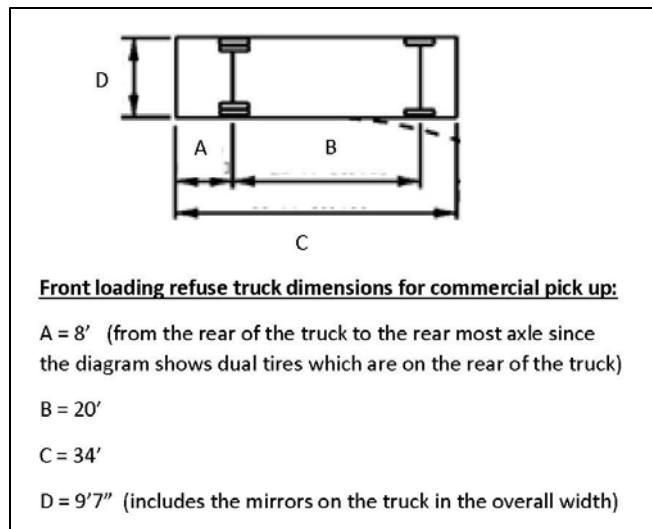

Paving & Screening requirements – see Township zoning ordinance